



# Myostat Motion Control Inc

---

## Cool Muscle

### CM1ipx Manual

### Hardware and Software

### TCP/IP communication protocol

Document Version 1.06

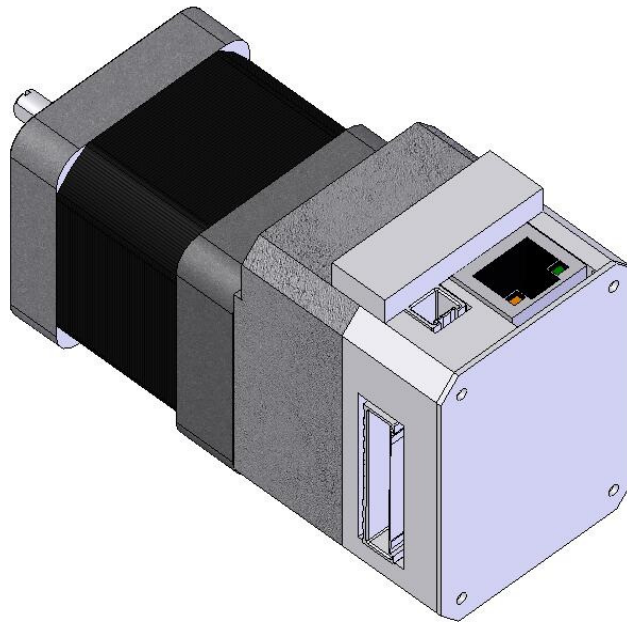

Myostat Motion Control Inc

+1 905 836-4441

[www.coolmuscle.com](http://www.coolmuscle.com)

# Table of Contents

<b>TABLE OF CONTENTS .....</b>	<b>2</b>
<b>1. GENERAL OVERVIEW.....</b>	<b>3</b>
1.1 HARDWARE AND WIRING.....	3
1.1.1 CM1ipx connection overview.....	3
1.1.2 Pinout descriptions .....	4
1.1.2.1 CN1 – 24V DC power.....	4
1.1.2.2 CN2 - Ethernet.....	4
1.1.2.3 CN3 – I/O.....	4
<b>2. CONNECTING OVER TCP/IP.....</b>	<b>6</b>
2.1 FINDING AND CONFIGURING THE CM1IPX MODULE .....	6
2.2 CONFIGURATION SETTINGS.....	7
2.2.1 0 – IP Address – Server configuration.....	8
2.2.2 1 – Baud rate – Serial port configuration.....	8
2.2.3 7 – Factory defaults .....	8
2.2.4 8 – Exit without save.....	8
2.2.5 9 – Save and exit.....	8
2.3 VIRTUAL COM PORT .....	8
<b>3. USING CWLITE.....</b>	<b>9</b>
<b>4. CML COMMUNICATION.....</b>	<b>9</b>

# 1. General Overview

The CM1ipx card enables TCP/IP communication to the CM1 Cool Muscle motor. The card acts as a communication bridge allowing data transfer with devices supporting TCP/IP.

## 1.1 Hardware and wiring

### 1.1.1 CM1ipx connection overview

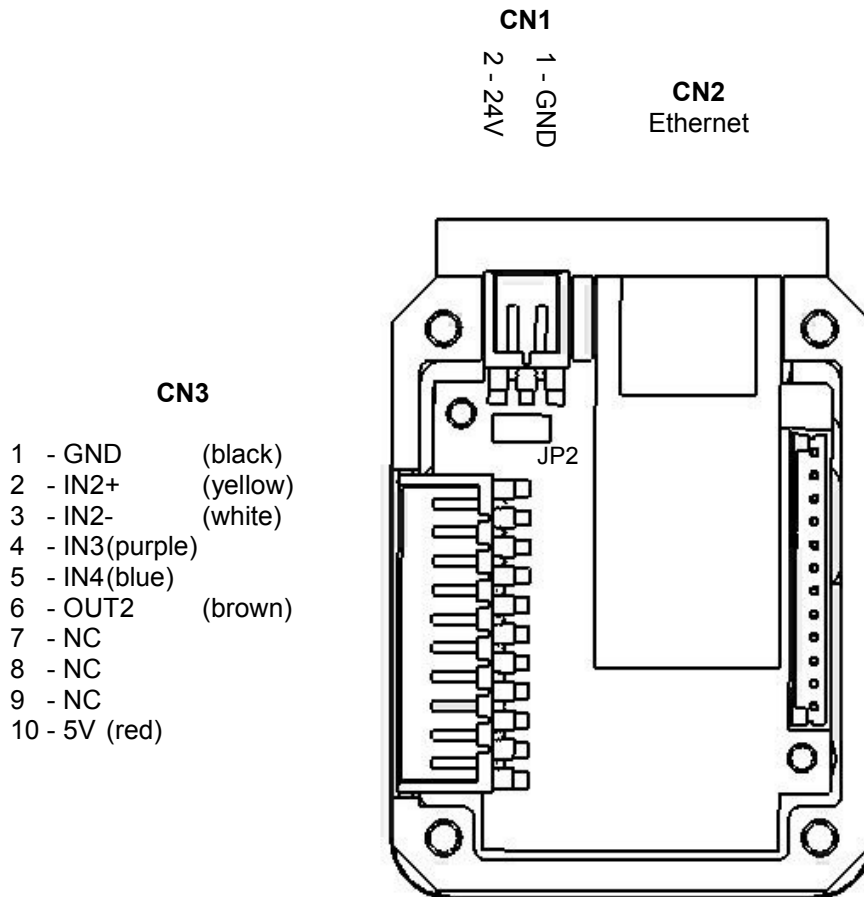

**Diagram 1: connection overview**

## 1.1.2 Pinout descriptions

### 1.1.2.1 CN1 – 24V DC power

CN1 is the power connector to the Ethernet module and the CM1 motor. The Ethernet module requires 250mA in addition to current supplied to the CM1. Refer to the motor's data sheet to find the motor current specifications.

- 1 – GND. Power ground
- 2 – 24V . Power 24V.

### 1.1.2.2 CN2 - Ethernet

CN2 is a standard RJ45 Ethernet connector.

### 1.1.2.3 CN3 – I/O

CN3 connects to the I/O on the CM1 motor. The ipx module passes through the I/O connections. For more information on the motor I/O please refer to the motor reference guide.

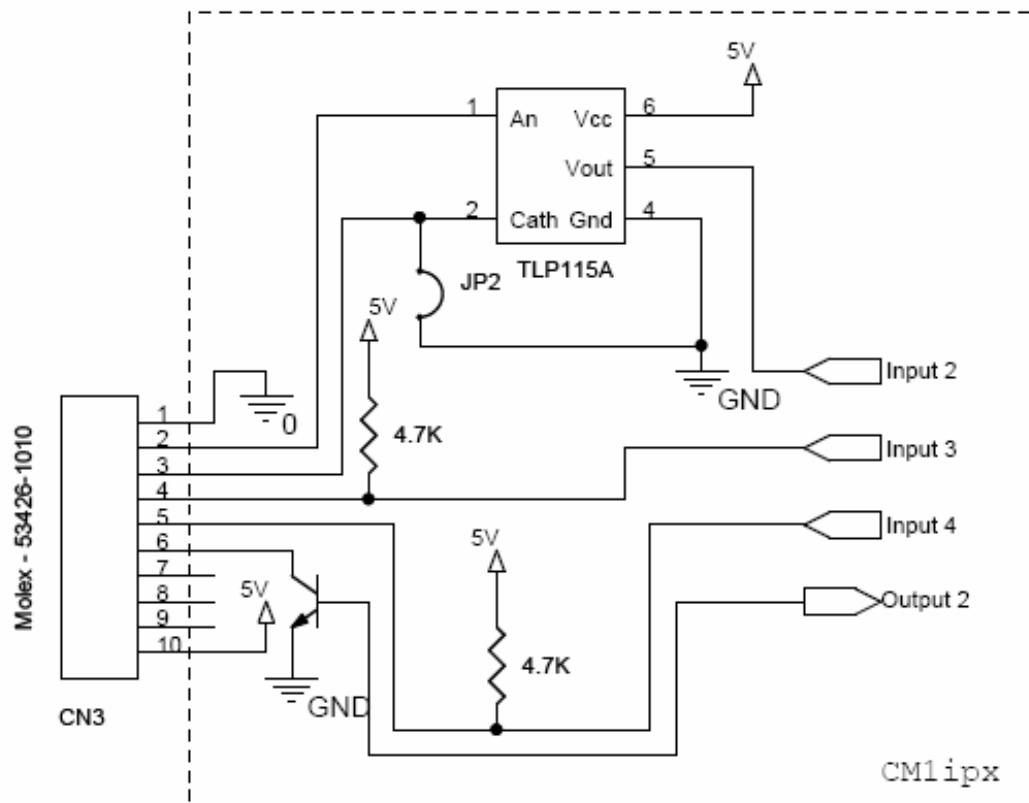

- 1 – GND
  - Signal ground
- 2 – IN2+
  - Positive input2 pin.
- 3 – IN2-
  - Negative input2 pin.
  - Optionally grounded internally with JP2 closed.
- 4 – IN3.
  - CM input3 pin.
  - Internally pulled up to 5V
  - Use with open collector output signal.
- 5 – IN4
  - CM input4 pin.
  - Internally pulled up to 5V
  - Use with open collector output signal
- 6 – OUT2
  - CM output2 pin
  - Open collector output
  - Pull-up to 5V~24V as needed.
  - 50mA max \*
- 7 - 9 – NC (no connection)
- 10 – 5V
  - 5V output
  - 50mA max \*

\* OUT2 and 5V output combined should not exceed 50mA.

## 2. Connecting over TCP/IP

The CM1ipx acts as a TCP/IP – Serial Bridge and allows for communication to a Cool Muscle through a TCP/IP connection. Any terminal/application that allows a TCP/IP port to be opened (e.g. HyperTerminal) can be used to communicate to the motor. CoolWorks Lite 4.1.6 and above has this functionality built in. The IP address must be known and used with port 10001

### 2.1 Finding and configuring the CM1ipx module

The CM1ipx is by default set up to connect to a DHCP server to obtain an IP address. Using the CM1ipx configuration tool (shown below) the module can be initially connected to and configured. The configuration tool is installed with CWLite version 4.1.6 and up.

The simplest process to configure the module is to have the computer running the configuration tool and the CM1ipx module connected to a common DHCP server.

If no DHCP server is available, the ipx module automatically configures itself using the RFC 3927 standard. The IP address is in the 169.254/16 range with a subnet mask of 255.255.0.0. Connecting directly from a PC to the module will show the module in the Configuration Tool. A switched or straight through RJ45 cable can be used to communicate. (The PC should either be set to DHCP in which case it will autoconfigure or have a static IP in the RFC 3927 range).

#### **Setting up the module:**

Connect all cables and power the module. Clicking the “Search for CM1ipx” should display the module in the box. Double clicking the module or highlighting it and clicking “Configure selected CM1ipx” will bring up the telnet configuration window for the module (see section 2).

Please note that the search tool will find additional Lantronix device servers on the network. Make note of the MAC address of the lipx module being set up and match it to the IP address shown. The MAC address can be found on the side of ipx module.

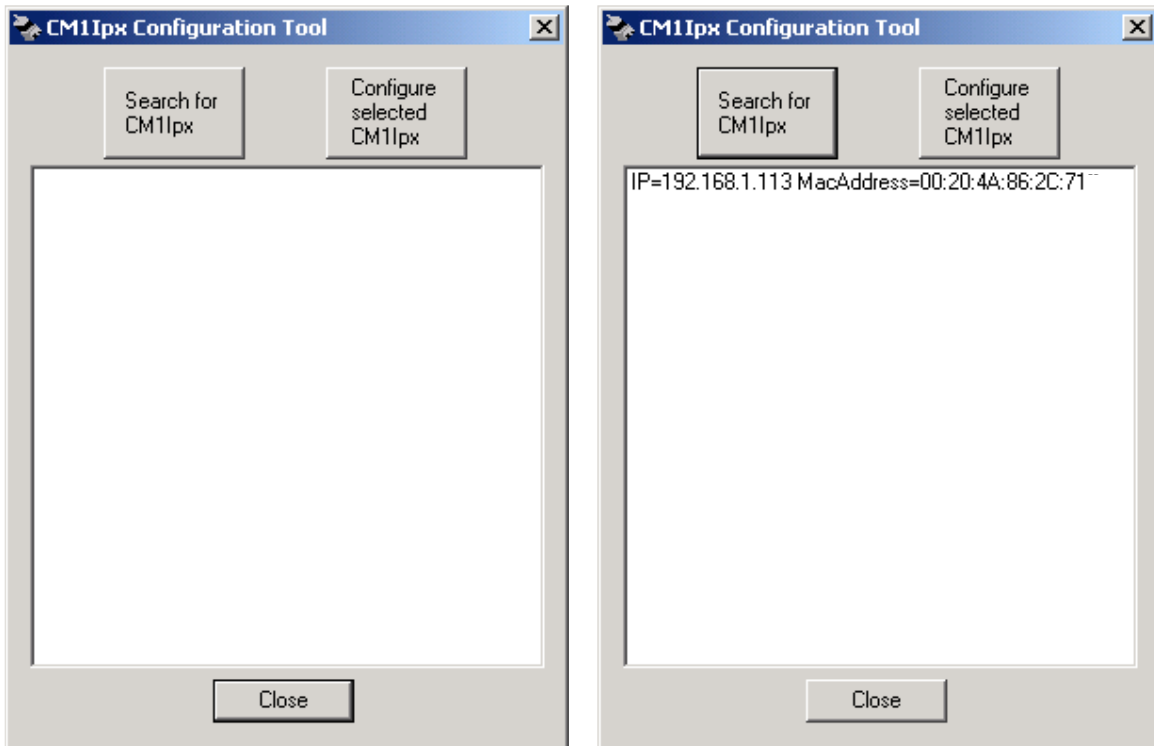

In the configuration window the network settings and IP address of the module can be set directly.

## 2.2 Configuration settings

Baud rate and IP address configuration can be set on the CM1Ipx. Changing these settings requires the user to Telnet to port 9999 on the module or to use the configuration tool to find and select the module.

```

C:\WINNT\system32\cmd.exe

*** Cool Muscle Ethernet Interface 1.0.0.2 ***
MAC address 00204A862C71
Software version 00.0.0.0 (080128) CPK6101_XPTX

Press Enter for Setup Mode

***** Cool Muscle Ethernet Interface 1.0.0.2 *****
***** Current Configuration *****
Baudrate 38.4K
TCP/IP is used.
Port number      : 10001
CPU performance  : High

Change Setup:
 0 Server configuration
 1 Serial port configuration
 7 factory defaults
 8 exit without save
 9 save and exit

Your choice ? _

```

### **2.2.1 0 – IP Address – Server configuration**

Basic TCP/IP settings can be set such as the IP address and gateway.

Dynamic IP: set to 0.0.0.0

Static IP: set the address as required.

### **2.2.2 1 – Baud rate – Serial port configuration**

The baud rate for CM1ipx controller to motor serial port can be set. This, however, does not set the baud rate on the motor. The motor baud should be set first by K20 before the CM1ipx baud is changed. Please note to take extra care doing this. If baud rates do not match communication becomes impossible. The CM1ipx will need to be returned to the manufacturer to be reset.

### **2.2.3 7 – Factory defaults**

Selecting 2 will automatically set the CM1ipx module back to factory defaults. Note: it does not set the motor back to factory defaults.

### **2.2.4 8 – Exit without save**

### **2.2.5 9 – Save and exit**

## **2.3 Virtual COM port**

The CM1IPX module can be connected to and communicated with via a virtual COM port. An example is the Lantronix CPR (COM port redirector). The virtual port should be set up with the IP address and port 10001.

### 3. Using CWLite

CWLite can connect with a CM1Ipx using the TCP/IP option. CWLite first opens with a splash screen that has an option for Serial or TCP/IP communication.

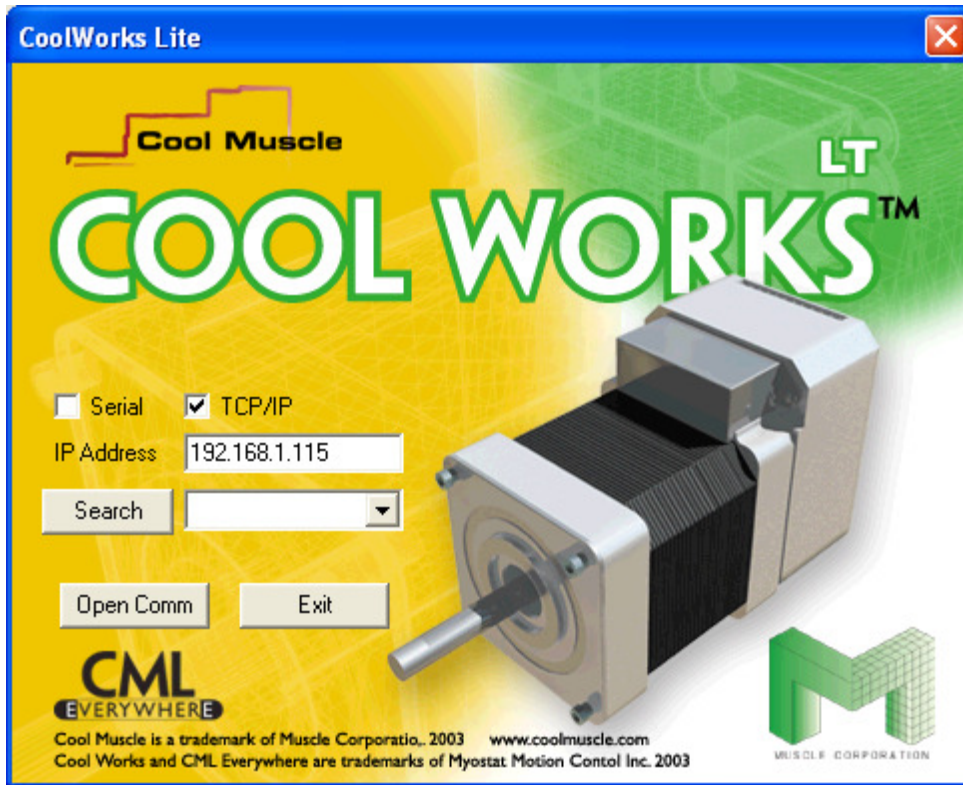

As can be seen in the above screen capture the TCP/IP option is selected and an IP address can be entered. The serial-ethernet bridge uses port 10001 and CWLite automatically sets this.

If the address is unknown there is a search button that will identify all ipx modules on the network and list them in the drop down box.

Clicking “Open Comm” will then open the communication to the motor on the selected IP address. At this point CWLite responds in the same fashion as a standard serial connection.

If a virtual COM port is set up, select serial and configure CWLite in the usual manner using a serial port.

### 4. CML communication

The CM1Ipx uses standard CML to communicate with and run the motor. Please refer to the CML reference guide for a list of commands and the command structure.

If command checking is required note that the motor responds and echoes character by character.